

# SIDEWALK REPAIR/REPLACE GRANT APPLICATION



**City of Blackfoot**  
PLANNING & ZONING DEPT  
157 N Broadway  
Blackfoot, Idaho 83221  
Phone 208-785-8600  
Fax 208-785-8602  
[www.cityofblackfoot.org](http://www.cityofblackfoot.org)

Owner Applicant Name: \_\_\_\_\_

Mailing Address: \_\_\_\_\_

Phone Number(s): \_\_\_\_\_

Email Address: \_\_\_\_\_

Project Location Address: \_\_\_\_\_

Project Description: \_\_\_\_\_

Size of Project: \_\_\_\_\_ square feet      Estimated Cost: \$ \_\_\_\_\_

**Attach Copies of Sidewalk Bid(s):** (If project is over \$1,800.00, two bids are required.)

\_\_\_\_\_ \$ \_\_\_\_\_

\_\_\_\_\_ \$ \_\_\_\_\_

Tree Removal Required:      Yes      No

**Attach Copies of Tree Removal Bid(s):** (If project is over \$1,800.00, two bids are required.)

\_\_\_\_\_ \$ \_\_\_\_\_

\_\_\_\_\_ \$ \_\_\_\_\_

## Certification:

By signing this application, I certify that, 1) I am the legal owner of the property where the proposed sidewalk repair project will take place, 2) that all information on this application and accompanying material is true and accurate to the best of my knowledge. If awarded a grant, I agree to comply with all the the rules and conditions set forth in the application packet and on the permit forms.

Signature: \_\_\_\_\_ Date: \_\_\_\_\_

Applications are available online at <https://blackfootportal.portal.iworq.net/portalhome/blackfootportal> and may be emailed to [mmyler@cityofblackfoot.org](mailto:mmyler@cityofblackfoot.org); or by mail to City of Blackfoot, Planning & Zoning Permits, 157 N. Broadway St., Blackfoot, ID 83221.      City of Blackfoot [cityofblackfoot.org](http://cityofblackfoot.org)

### FOR OFFICE USE ONLY

Project Approved By \_\_\_\_\_ Date \_\_\_\_\_

### REQUIRED INSPECTIONS

Forms \_\_\_\_\_ Date \_\_\_\_\_      Final \_\_\_\_\_ Date \_\_\_\_\_

### REIMBURSEMENT REQUEST APPROVAL

Mayor \_\_\_\_\_ Date \_\_\_\_\_

P & Z Administrator \_\_\_\_\_ Date \_\_\_\_\_

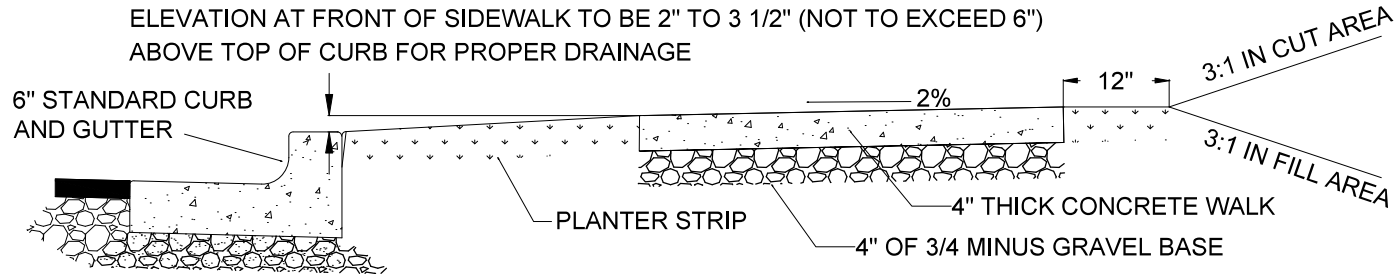
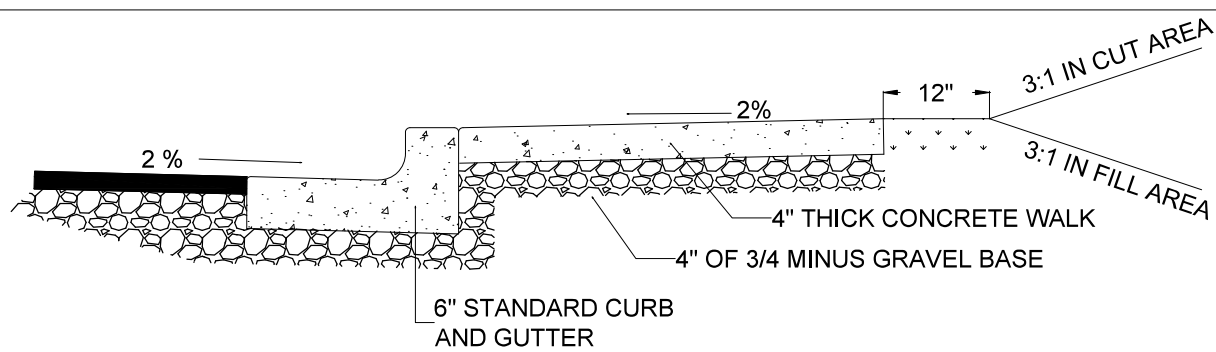

**NOTES:**

- A. LOCATION, GRADE & WIDTH OF SIDEWALK TO BE ESTABLISHED OR APPROVED BY OWNER.
- B. GRAVEL BASE UNDER CONCRETE TO BE COMPACTED TO 95% OF STANDARD DENSITY
- C. SLOPE DRIVEWAY TOWARDS THE STREET NOT TO EXCEED 1.75% ± 0.25% UNLESS OTHERWISE SPECIFIED BY THE OWNER.
- D. SCORE AT INTERVALS TO MATCH WIDTH OF SIDEWALK NOT TO EXCEED 5 FEET SPACING. IN BOTH THE LONGITUDINAL AND TRANSVERSE DIRECTION FOR SIDEWALKS GREATER THAN 5 FEET IN WIDTH.
- E. 1/2" TRANSVERSE PREFORMED BITUMINOUS AT THE TERMINUS POINTS AT CURVE AND WHERE SIDEWALK IS PLACED BETWEEN TWO PERMANENT FOUNDATIONS OR ADJACENT TO A STRUCTURE, PLACE 1/2" EXPANSION JOINT MATERIAL ALONG THE BACK OF THE WALK THE FULL LENGTH.
- F. DRIVEWAY APPROACH ACROSS PLANTER STRIP TO BE 5" MINIMUM CONCRETE OVER 4" OF 3/4" MINUS CRUSHED BASE.
- G. SIDEWALK CONSTRUCTION JOINTS SHALL BE CONSTRUCTED APPROXIMATELY 1/8" WIDE 3/4" IN DEPTH AND FINISHED AND EDGED SMOOTH. A PREFORMED EXPANSION JOINT FILLER SHALL BE PLACED EVERY 40' FOR NEW SIDEWALK CONSTRUCTION.
- H. ALL CONCRETE SHALL BE CLASS 3000 PER SECTION-703 ISPWC, UNLESS NOTED OTHERWISE.
- I. STAMP EVERY 150 FEET WITH DATE OF INSTALLATION

 <p>CITY OF BLACKFOOT</p>	PROJECT NAME AND ADDRESS	DISCUSSION	
	CITY OF BLACKFOOT	DETAILS:	
	STANDARD DETAILS	DATE	SHEET
	<b>SIDEWALK DETAILS</b>	12/13/2019	BSD 6
		SCALE	
		NTS	